



INSTRUCTION

RALLYE FORGED WHEEL KIT

2018.07.20

10吋鍛造拉力輪圈組
S/N : 196 500 0XX

適用機型 : GOGORO 1 15'-

零件 :

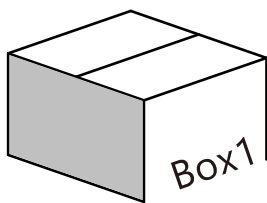

前輪圈本體
Front wheel base
x 1

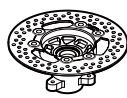

輪圈碟盤座
Brake disk seat
x 1



輪圈蓋
cover
x 2



前卡鉗座
Front caliper seat
x 1



氣嘴
Valve
x 2



前剎車油管
Front Brake pipe
x 1



後剎車油管
Rear Brake pipe
x 1

(包含油管螺絲等配件) (包含雙孔油管螺絲等配件)

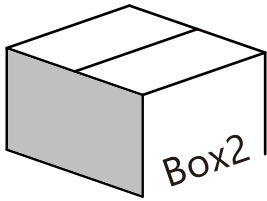

後輪圈本體
Rear wheel base
x 1

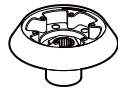

後輪殼
Rear Hub
x 1
(已預先安裝)



後卡鉗座
Rear caliper seat
x 1



前卡鉗固定螺絲
M10x1.5-20mm
x 2



後卡鉗固定螺絲
M8x1.25-20mm
x 2



前卡鉗座固定螺絲
M8x1.25-25mm
x 2



前輪圈固定螺絲
M8x1.25-20mm
x 3
(6支已安裝於後輪殼)



輪圈蓋固定螺絲
M5x0.8-6mm
x 12

輪胎尺寸規格表 :

前輪

扁平比	規格	胎寬m/m	胎高m/m	寬度差	圓周差
原廠(60)	100/60-12	100	424	0.00%	0.00%
80	100/80-10	100	414	0.00%	2.36%
90	100/90-10	100	434	0.00%	-2.36%
	90/90-10	90	416	10.00%	1.89%
100	3.0-10	83	414	17.00%	2.36%

後輪

扁平比	規格	胎寬m/m	胎高m/m	寬度差	圓周差
原廠(60)	110/60-12	110	436	0.00%	0.00%
80	110/80-10	110	430	0.00%	1.38%
90	110/90-10	110	452	0.00%	-3.67%
	100/90-10	100	434	9.09%	0.46%
100	3.5-10	97	435	11.82%	0.23%

煞車卡鉗對應表 :

前輪

基本鑄造	型號
對向四活塞(左)	30/34 M
鍛造鋁錠車削	
對向四活塞(左)	30/34 M

後輪

基本鑄造大螃蟹	型號
對向雙活塞	P34/84M



INSTRUCTION

RALLYE FORGED WHEEL KIT

Part 1. 前輪 Front wheel

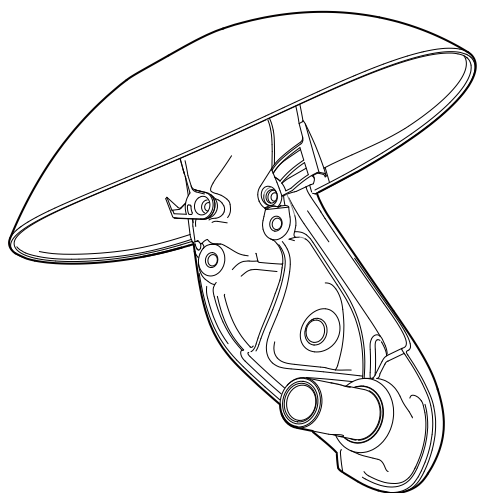
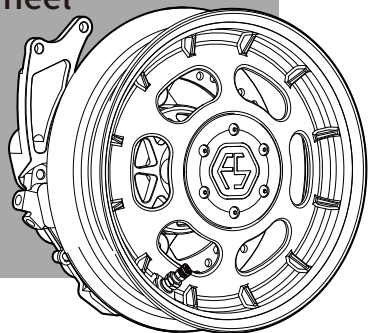

⚠ 注意

*改裝、非標準安裝或安裝於非專用機型，將會失去產品保固服務。

詳細保固政策請參考www.fass.com.tw

**安裝前請先檢查產品外觀，如發現瑕疵，請勿安裝，並立即與我們聯絡。

service@fass.com.tw

***清潔保養可使用一般中性清潔劑清洗，勿使用強酸性或強鹼性清潔劑。

⚠ 胎皮及氣嘴請預先安裝

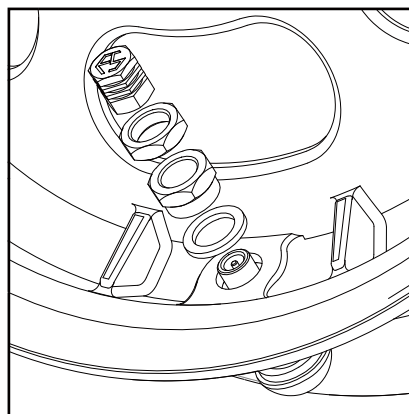

Step 1. 依序卸下原廠前輪圈、卡鉗座、卡鉗、油管、輪轂碟盤，並以本產品專用煞車油管替代原廠煞車油管，完成後如圖所示。

Step 2. 鎖上原廠卡鉗座，並放上碟盤座。

✓ 建議扭力值27.0Nm

⚠ 勿與輪圈固定螺絲混淆

M8-1.25-25mm x2

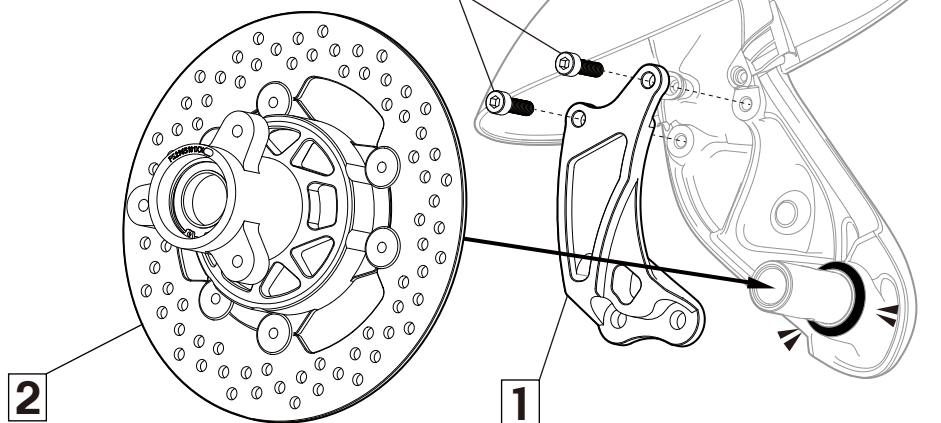



INSTRUCTION

RALLYE FORGED WHEEL KIT

Step 3. 將油管鎖上卡鉗，並將卡鉗固定至卡鉗座上。

✓ 建議扭力值40.0Nm

⚠ 務必確認碟盤位置在來令片之間置中

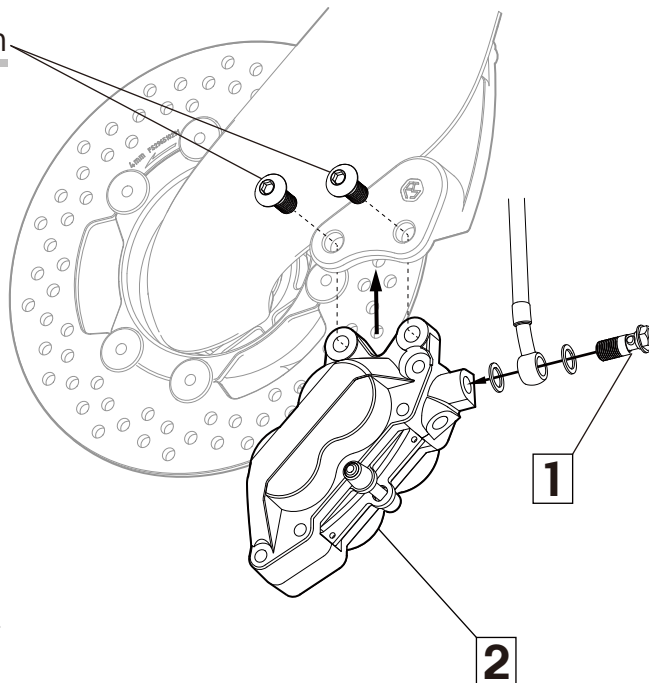
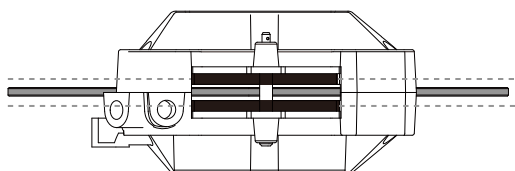

Step 4. 依序鎖上原廠軸承固定螺絲、

✓ 建議扭力值5.0Nm **3**

⚠ 勿與前卡鉗座螺絲混淆
M8-1.25-20mm x3

✓ 建議扭力值25.0Nm **2**

✓ 沿用原廠螺絲
建議扭力值24.0-30.0Nm **1**

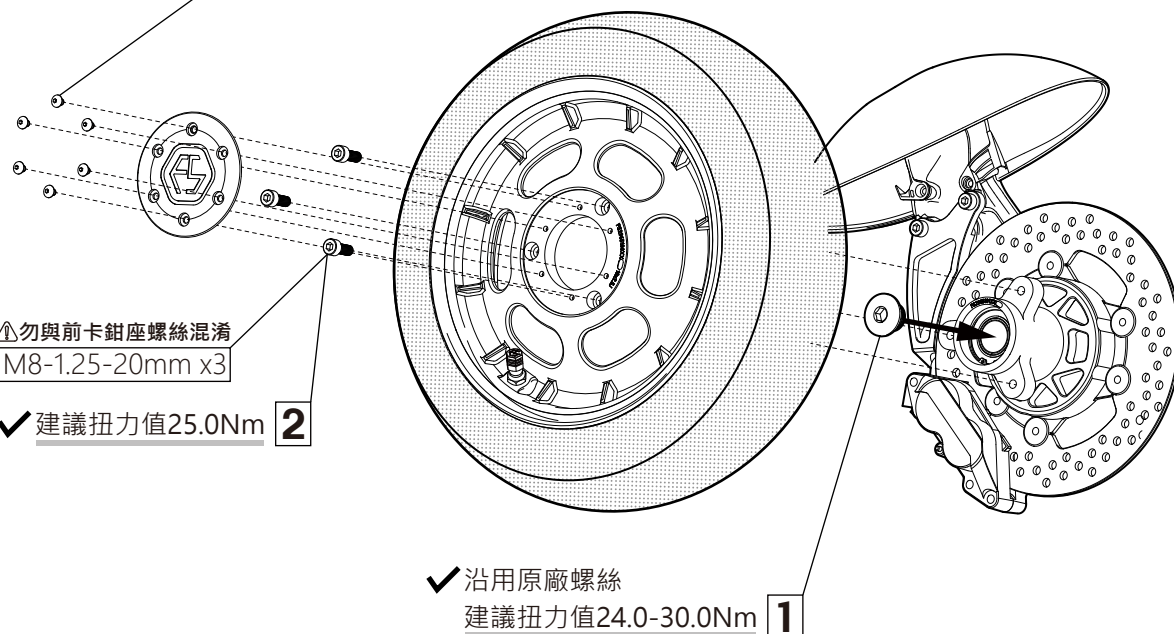



INSTRUCTION

RALLYE FORGED WHEEL KIT

Part 2. 後輪

Rear wheel

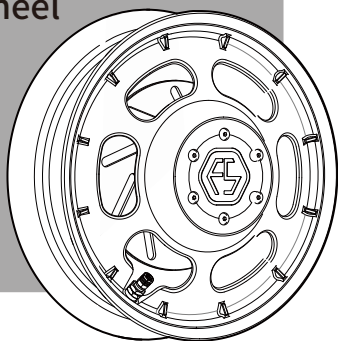

⚠ 胎皮及氣嘴請預先安裝

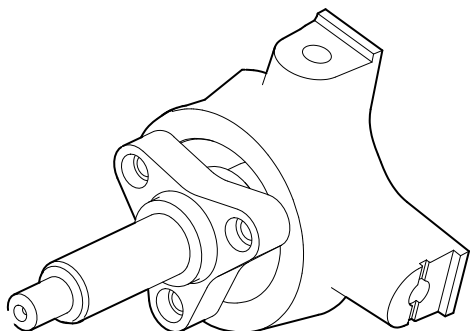
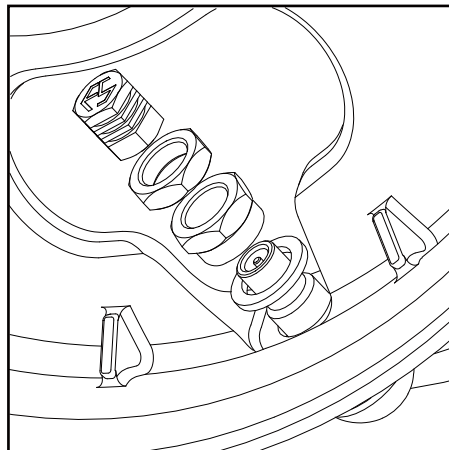

Step 1. 依序卸下原廠後輪圈、碟盤、卡鉗座，
完成後如圖所示。

✓ 先鬆開碟盤螺絲後，再依序卸下卡鉗、碟盤。

⚠ 如未改裝Brembo卡鉗，則只需卸下輪圈即可，
直接跳至步驟3。

Step 2. 將剎車油管鎖上卡鉗座後，卡鉗座放至定位並鎖上螺絲。

⚠ 如未改裝Brembo卡鉗，請忽略此步驟。

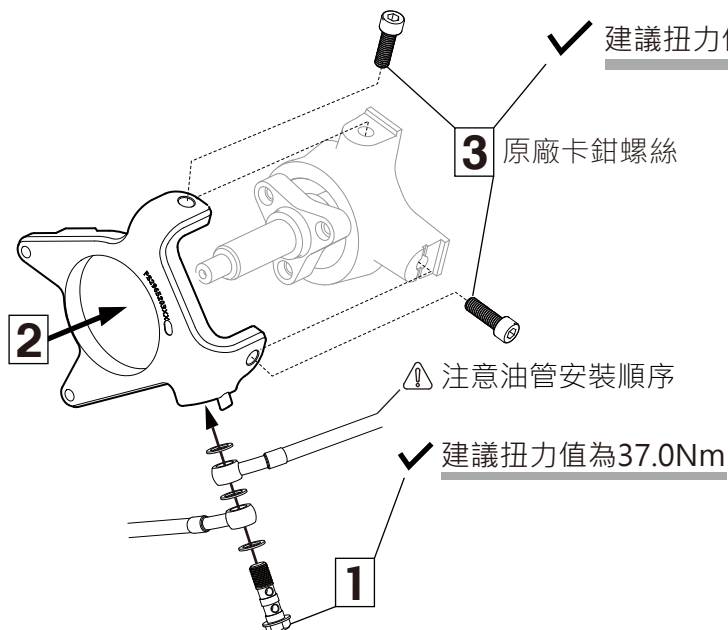

⚠ 注意油管與定位柱相對方向

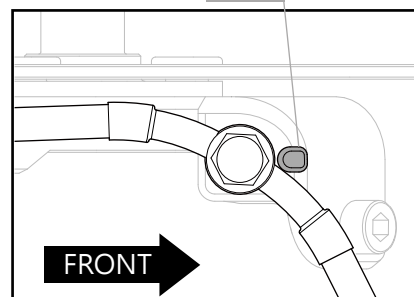



INSTRUCTION

RALLYE FORGED WHEEL KIT

Step 3. 將HUB鎖上輪圈。

✓ 螺絲建議扭力值為25.0Nm

M8-1.25-20mm x6

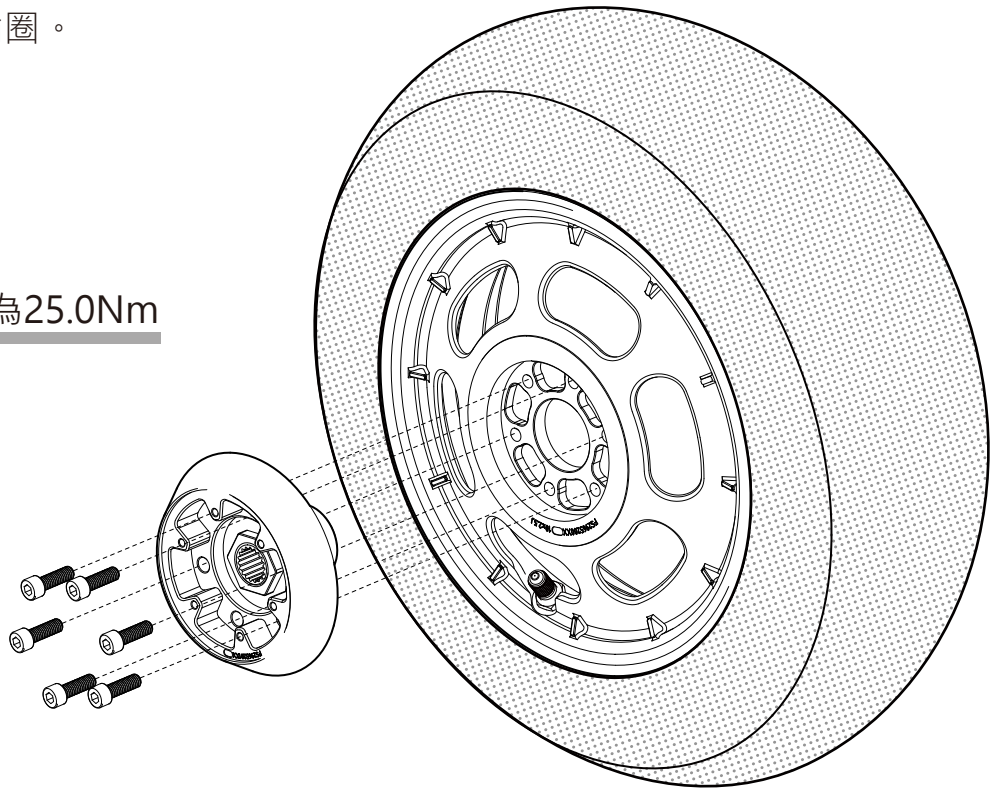

Step 4. 依序先裝上碟盤（螺絲牙先含住即可），再鎖上卡鉗本體，
按住剎車後逼緊碟盤螺絲。

✓ 建議扭力值27.0~30.0Nm **2**

✓ 建議扭力值27.0~33.0Nm **1**

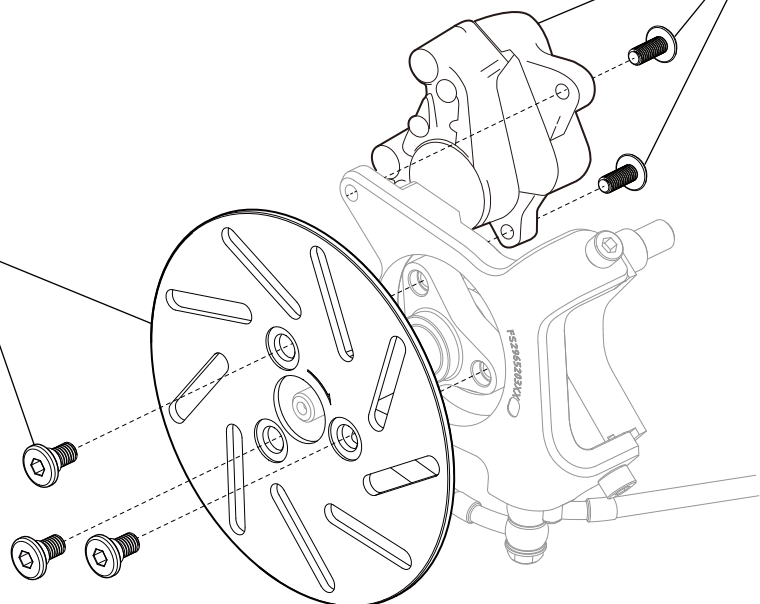



INSTRUCTION

RALLYE FORGED WHEEL KIT

Step 5. 先放上碟盤鎖上螺絲，安裝上卡鉗後
再將碟盤螺絲逼緊。之後依序安裝上
輪圈及輪圈蓋。

✓ 沿用原廠螺母

建議扭力值85.0~90.0Nm **2**

✓ 建議扭力值5.0Nm **3**

